

NOTES:

- PART DESIGNED IN METRIC.
- TERMINAL FOR USE WITH 5557 SERIES HOUSINGS.
- MATES WITH 5558, 5566 AND 5569 SERIES CONNECTORS.
- REFER TO DWG. NO. CS-5556*/5558* FOR CRIMP SPECIFICATIONS.
- PRODUCT SPECIFICATION AND PROCESSING PARAMETERS SEE: PS-5556-001, PS-5556-002, PS-5556-003

MATERIAL:

- CDA 260 BRASS, .0080±.0004/(0.203±0.010) THICK.
- CDA 510 PHOS. BRONZE .0080±.0004/(0.203±0.010) THICK.

PLATING:

- A. SELECTIVE GOLD PLATE .000030/(0.00076) MIN., AND SELECTIVE MATTE TIN .000100/(0.00254) OVER .000050/(0.00127) NICKEL OVERALL.
 - B. SELECTIVE GOLD PLATE .000015/(0.00038) MIN., AND SELECTIVE MATTE TIN .000100/(0.00254) OVER .000050/(0.00127) NICKEL OVERALL.
 - C. SELECTIVE GOLD PLATE .000050/(0.00127) MIN., AND SELECTIVE MATTE TIN .000100/(0.00254) OVER .000050/(0.00127) NICKEL OVERALL.
- THE PRIMARY SHIPPING CARTON WILL BE LABELED "COMPLIANT TO RoHS DIRECTIVE 2002/95/EC AND ELV ANNEX II OF DIRECTIVE 2000/53/EC." CARTONS WITHOUT THIS LABEL MAY CONTAIN PRODUCT WITH TIN-LEAD PLATING.

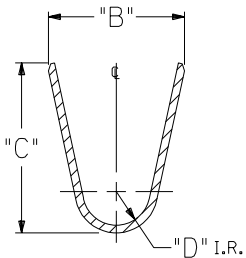
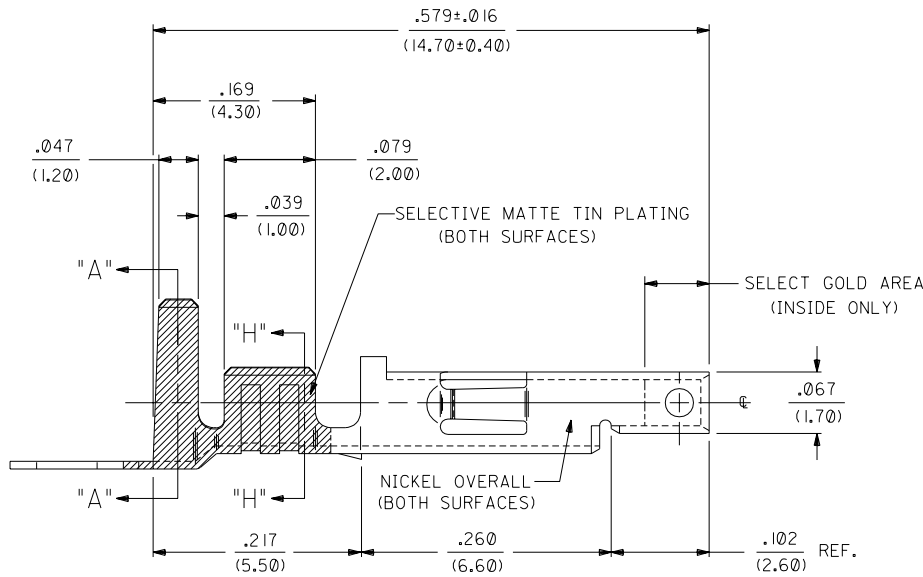
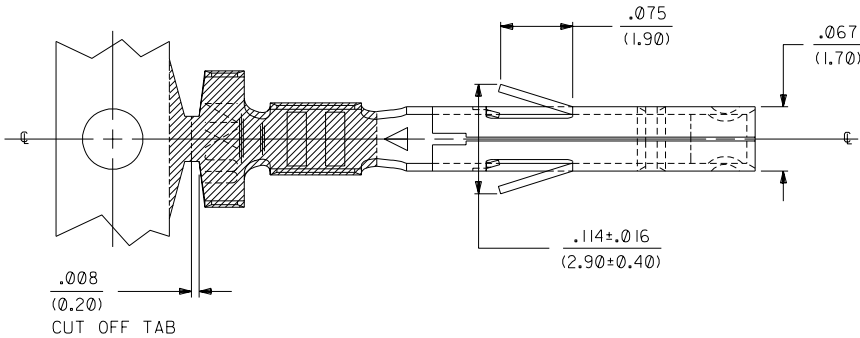

SECT. "A-A"

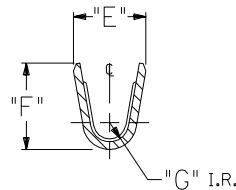

SECT. "H-H"

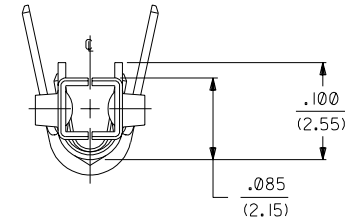

F	ADD PS NOTE UCP2004-1755 MSC
E	ADD PS NOTE UCP2003-0365 ECN #140405 8/29/2002 SAMIEC
D	REV. 28-30 CA.DIM ECN #140405 94-04-06 A.GUZZIK
C4	ADDED EDP'S PER ECN U21346 9-9-92 RJF
C3	REVISED 28-30 AWG ECN U21318 9-3-92 RJF
C2	REVISED PER ECN U20109 2-19-92 RJF
C1	ADDED 30AWG CRIMP ECN U12258 12-2-91 RJF
C	ADDED 14AWG CRIMP ECN U12028 10-15-91 RJF
B	REDRAWN PER ECR U100382 5-17-90 RJF

DIMENSIONS SHOWN (METRIC) INCH		▽ = 0		◻ = 0		REVISE ONLY ON CAD SYSTEM	
UNLESS OTHERWISE SPECIFIED TOLERANCES: ANGULAR ± 1/2°							
INCH		METRIC		TITLE			
3 PLACE	± .010	---	---	TERMINAL, MINI-FIT JR., FEMALE, CRIMP, SELECT GOLD BLANK-PLATE-FORM			
2 PLACE	± .014	± 0.25	---	MOLEX INCORPORATED			
1 PLACE	---	± 0.36	---	SHEET NO. 1 OF 2 DATE 5/17/90			
DRAFT WHERE APPLICABLE MUST REMAIN WITHIN DIMENSIONS				PART NO. SD-5556-GSP*			
DRWG. BY: GEP	CHK'D. BY: RJF	SCALE: 10:1		FILE NAME: 55556.IX1		DIV. CP	
APP'D. BY: RAS	SCALE: 10:1			THIS DRAWING CONTAINS INFORMATION THAT IS PROPRIETARY TO MOLEX INC. AND SHOULD NOT BE USED WITHOUT WRITTEN PERMISSION		SIZE	

5556